

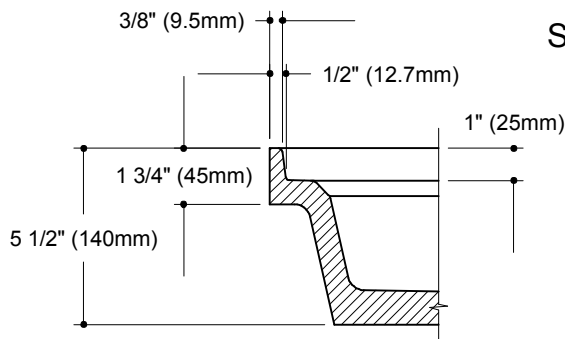

**MARSHALL  
GRUBER  
COMPANY**

Toll-Free: 866-260-6457 (from the U.S. only)  
 Web: <http://marshallgruber.com>  
 Email: [info@marshall-gruber.com](mailto:info@marshall-gruber.com)  
 Address: 220 Airport Drive, Mansfield, TX 76063

## MOLD SPECIFICATIONS

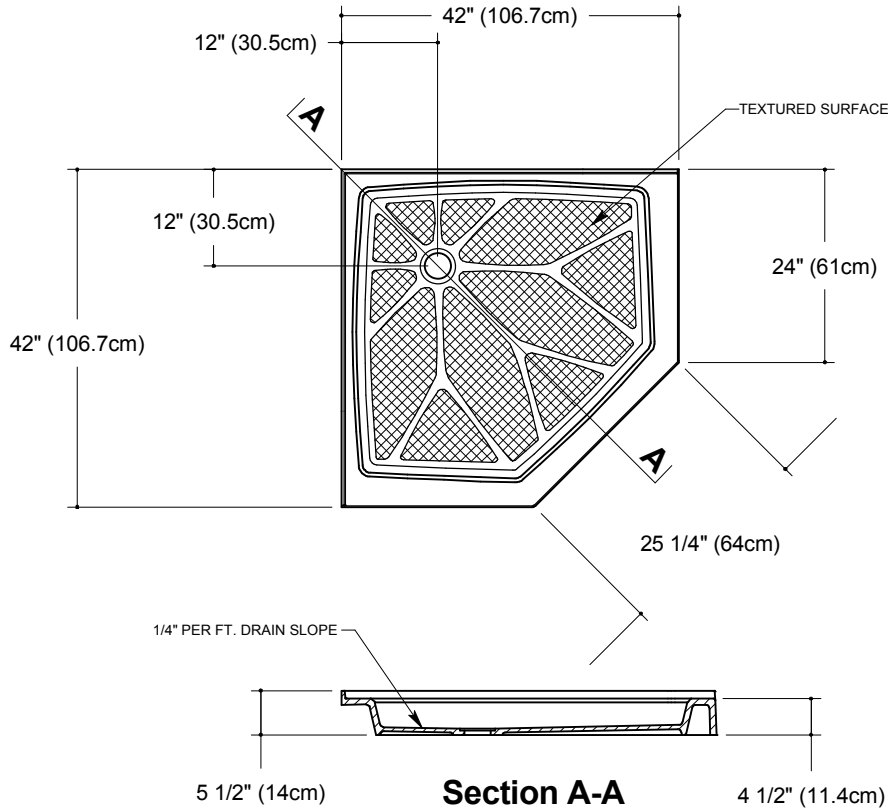

Sections showing water dam and drain details.  
 (Lightweight option not shown)

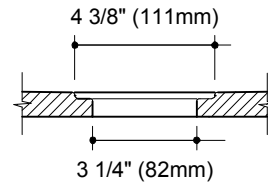

**Cast Weight Specs:** Gross Weight = 230 lb; Net Weight (w/ Insert) = 159 lb; Net Weight (w/ Turtle) = 127 lb

MOLD PART	CATALOG NO.	DESCRIPTION
MALE	23064	Mold, Male, 1051-14 Corner Shower Pan 42" x 42" (107 x 107 cm)
FEMALE	430648	Mold, Female (F), 1051-14 Insert
	430649	Mold, Lightweight Female 1/2" (ULFF), 1051-14 Combo Insert
<b>NAME 1051-14 CORNER SHOWER PAN 42" X 42" MOLD</b>		
CAST WT: See above	SCALE: 1/2" = 1'0"	DATE: 3-8-19